

### About FaceTime IM Auditor MT

IM Auditor Multi-Tenant (MT) enables Managed Service Providers (MSPs) to offer a branded, hosted IM security, control and compliance solution to businesses of any size, providing a logical service line extension to existing outsourced applications, such as VPN and email.

### KEY MANAGED SERVICE PROVIDER (MSP) FEATURES

- High performance
- Linear scalability
- Carrier-grade availability
- Data center-class manageability
- Low incremental cost
- Proven in the field

### KEY END USER FEATURES

- Creates a standardized profile of all real-time communications use
- Automatically protects against greynet threats identified by FaceTime Security Labs
- Identity management with policy control at global, group and employee levels
- Prevents loss of intellectual property and confidential information over IM
- Scans file transfers using existing antivirus installation
- Guaranteed 100% accurate binary archiving of all IM
- Sophisticated workflow process for regulatory compliance monitoring
- Prevents SpIM to protect bandwidth and close security holes
- Blocks zero-day IM-based worm and virus attacks
- Secure, intuitive Web-based administration and reporting

IM Auditor has been deployed by a number of leading MSPs, including Reuters, Sector, British Telecom, AmeriVault, eVault and Global Relay. The technology is used by the world's largest firms to secure and manage real-time communications and ensure that both public and enterprise instant messaging networks are safely used to enhance business productivity and responsiveness without endangering the organization's information security. IM Auditor MT is specifically designed to extend this technology to service providers, opening up a broad additional revenue stream without adding significant operational cost increases.

### Hosted IM Security a Growth Opportunity

IM is the fastest growing electronic communications medium in history; presence is today's dial tone, and enterprises are clearly deriving significant benefit from fast, effective communication. Industry analysts expect Enterprise IM (EIM) to reach 100% adoption by 2010, with Public IM (PIM) clients reaching market saturation even sooner. EIM products are moving rapidly towards becoming unified communication and collaboration platforms integrating a wide range of real-time communications tools. Along with PIM services and industry-focused IM communities, they provide the ability for employees to communicate with one another as well as with customers, partners, and others outside the corporate network.

According to Osterman Research, more than 10% of organizations under 2,500 employees have chosen a hosted solution for IM deployment; this number is expected to double over the next two years.

### Liability Risks of IM for the Organization

IM threads, along with the chat threads created through the use of web conferencing and VoIP applications such as Skype, and any files transferred across these networks, are subject to the same legal controls and compliance requirements as email and web traffic. Compliance officers, information security managers, and network administrators are required to safeguard and archive these conversations for auditing purposes and to ensure data privacy legislation breaches do not occur.

Organizations need to protect the network from malicious threats, prevent loss of confidential information and intellectual property, enforce corporate policy, monitor and archive IM conversations for regulatory compliance. Hosted IM security and compliance management enables organizations with limited IT resources to meet these requirements without the complexity and ongoing expense of deploying internal solutions.

### A Proven Solution

IM Auditor is the most mature and wide-ranging security and compliance solution for IM applications available today, supporting the full range of PIM and EIM applications, professional community networks, and Web conferencing applications. Backed by FaceTime Security Labs, the industry's largest greynet research team, IM Auditor delivers TrueCompliance™ - guaranteed compliance support for all major federal and industry regulations through multi-layered policy-based access control, monitoring, and insight into the use of real-time communications tools.

IM Auditor protects real-time communications channels against viruses and other malware through integral support for existing anti-virus installations, effectively closing the zero-day gap. Patent-pending anti-SpIM (Spam over IM) keeps IM networks free of bandwidth-hogging spam, and intelligent, granular content filtering and archiving/logging of all electronic conversations ensures an audit trail for information leak prevention and compliance. IM Auditor enhances the security and compliance capabilities of EIM networks like IBM Lotus Sametime and Jabber.



IM Auditor MT gives service providers the ability to quickly and cost-effectively fulfill the growing demand for outsourced IM management, compliance, application integration, and security controls, regardless of end user organization size or market segment.

By taking the hosted route to IM management and compliance, end-user customers gain a full-featured solution at low prices and nominal cost of ownership, thanks to the unique capabilities specifically designed into the IM Auditor product line.

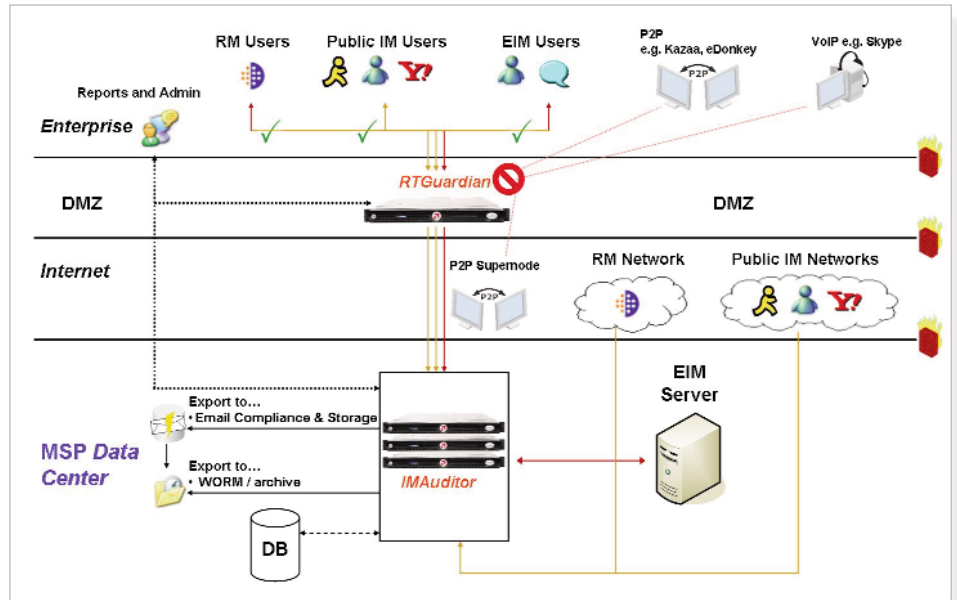

## IM AUDITOR MT FEATURES

### MSP BENEFITS

- High performance
  - Each IM Auditor server exhibits the same performance as for the internally-managed model
- Scalability
  - IM Auditor servers can be clustered to boost performance through linear scaling
- Manageability
  - MSP partners have access to IM Auditor deployment management interface
  - On and off-premise directory synchronization
- Flexibility
  - End user customers have access to IM policy management and compliance reviewer interface
- Security
  - Secure mapping
  - Mutual privacy
  - Customer data isolation
- Cost-effective
  - MSPs can provision customers of all sizes generically on the IM Auditor infrastructure in their data center or network operations center, adding hardware resources as needed to accommodate growth.

The Service Provider Administrator interface offers the following controls for each customer:

- Dashboard provides IM activity by company, network usage, and audit events
- Companies tab enables efficient setup of networks accessed and company administrators
- Flexible and granular reporting available by company or networks
- Configuration tab creates global company policies and company defaults

### END USER CUSTOMER BENEFITS

#### Security

- Anti-virus-scanning of file transfers (McAfee, Symantec, TrendMicro, CA, Sophos)
- File transfer permissions by size, domain, and by file type
- URL blocking

#### Policy Management

- Identity control (requires VPN access)
  - LDAP directory integration
- Access and usage policies
  - Flexible group-level ethical boundaries ("Chinese Walls")
  - File transfer permissions

#### Compliance

- Full binary message capture to record hidden messages
- Single-step guaranteed strict archiving into email/WORM storage

### DATA CENTER INFRASTRUCTURE REQUIREMENTS

- Hardware requirements:
  - Pentium IV 2GHz CPU or higher recommended
  - 1 GB of RAM
  - 30 GB available hard disk space
  - Any leading commercial load-balancer
    - Cisco Content Service Switch
    - Alteon ACEdirector
    - Foundry ServerIron
    - F5 BigIP
- Software requirements
  - MS Windows 2000/2003 server or Linux Red Hat ES 3.0
  - MS SQL Server 2000 or Oracle 9i or 10g
- Performance
  - Up to 15,000 users per standard machine (100 IMs/sec, fully-burdened)
  - Up to 30,000 on dual-NIC machine; more with MUX connections (R&D)
- Supported Networks:
  - Enterprise Instant Messaging: IBM Lotus Sametime, Jabber,
  - Professional Community Networks: Reuters, Bloomberg, Communicator Inc.,
  - Web Conferencing: WebEx
  - Public Instant Messaging: MSN, AIM, Yahoo!, GoogleTalk, and more